

ISO 9001:2008
ISO 22000:2005

 NICHROME



SPRINT PLUS SERIES





Sprint Plus Auger



Sprint Plus Multi Head Weigher

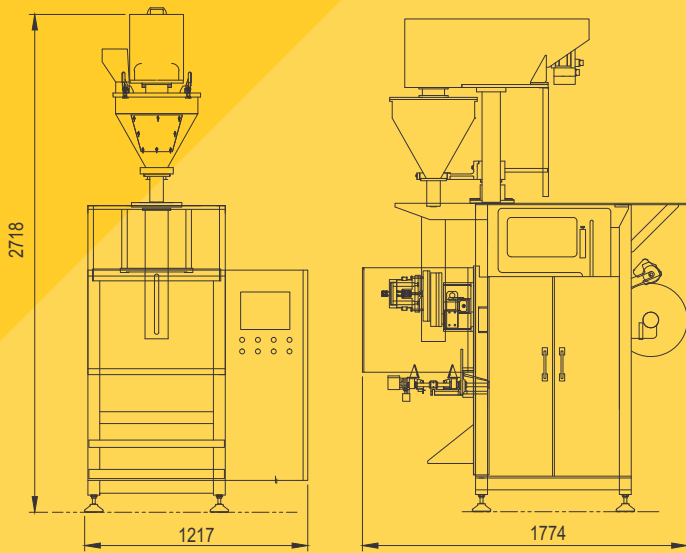

Front View

Side View

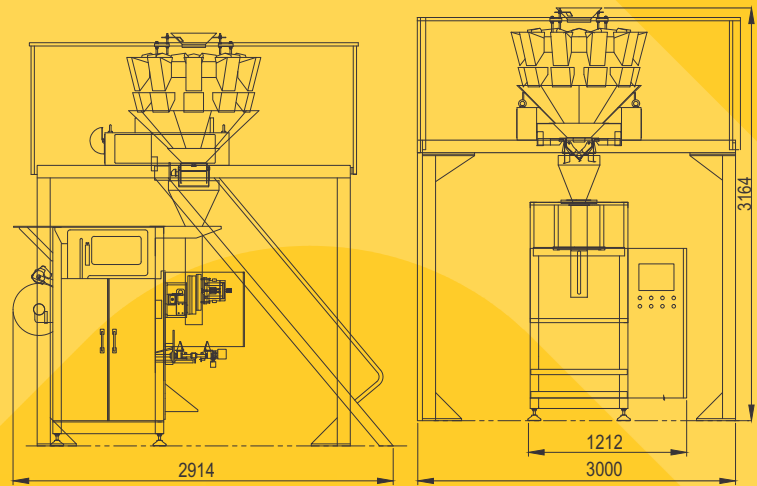

Front View

Side View



Application: Milk Powder, Dairy Whitener, Ground Spices, Pharma Powder, Coffee, ORS, Aata, Detergent, pesticides, Chemical powders



Application: Chips, Puffed snacks, Namkeen, Dry Fruits, Wrapped Candies, Macaroni, Biscuits, Pasta, Seeds, Breakfast Cereals





Sprint Plus Electronic Weigh Filler



Sprint Plus Cup



Front View

Side View

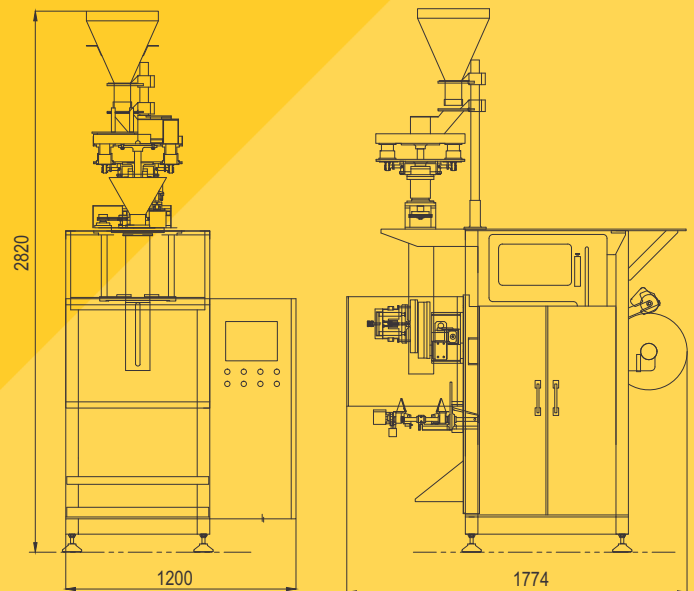

Front View

Side View



Application: Grains, Pulses, Rice, Tea, Sugar, Whole Spices, Dry Fruits, Seeds, Candies



Application: Grains, Seeds, Granules, Detergent, Sugar



Salient Features

- PLC based machine
- Single or perforated chain of pouches can be produce.
- Compact and versatile design.
- Designed for minimum product fall
- Motorized film roll unwinding.
- Auto tuning PID type temperature controller.
- Touch screen interface.
- Totally enclosed & dust-proof construction.
- Pneumatically operated Horizontal Sealing for three side seal & Center Seal Pillow Pouch
- Optional servo operated horizontal sealing for CSPP
- Interface with PC and data processors (optional).
- For higher output Double head model available.
- Built in static charge eliminator.
- Pre & post material handling system available on request.
- Servo belt draw off system for positive & accurate film pulling.

Filler Options

- Auger Filler
- Multi Head Weigher
- Linear Weigher
- Cup Filler
- Visco Filler / Piston Filler
- Gate Weigher

Optional Accessories

- Print mark scanner.
- Printing options - Hot Foil Printer, Inkjet Printer & TTO (Thermal Transfer Over Printer).
- Dust collection system.
- Inert gas flushing / modified atmosphere system.
- Auto web tracking system.
- Anti trickling system.
- Dynamic checkware.
- Baling solution for post packaging.
- Punch hole in horizontal sealing.
- Metal detector
- Straight line cut

Pouch Formation Mechanism

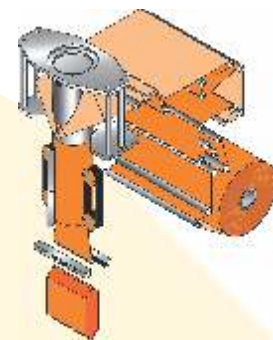

Machine Specifications - Sprint Plus Series Bagger

Machine	Sprint Plus	Machine	Sprint Plus
Rated output (max upto)		Max. Pouch Size (W x L) approx.	
Laminate	120 pouches / min	Center Seal Pillow Pouch	220 mm x 330 mm
Co-Ex	40 pouches / min	3 Side Seal	200 mm x 330 mm
Quantity (Depends upon product's bulk density)	upto 1 kg (25 cc to 2000 cc)	Supply Voltage	415 V AC 3 ph, 50 Hz
Min. Pouch Size (W x L) approx.		Connected Load	3 Kw
Center Seal Pillow Pouch	70 mm x 80 mm	Air Consumption approx.	28 metre ³ / hr @ max speed (at 5 Bar)
3 Side Seal	75 mm x 80 mm	Machine Dimensions (W x D x H) approx.	1200 mm x 1610 mm x 1700 mm
		Packaging Material	Heat Sealable Laminate, Co-extruded Films

Pouch Styles



Center Seal
Pillow Pouch (CSPP)



Center Seal
Gusset Pouch (CSGP)



3 Side
Seal Pouch



4 Side
Seal Pouch



Offset
Seal Pouch



Stand Easy
Pouch



NICHROME

NICHROME INDIA LTD.

Registered Office : Safire Park Galleria, 4 Pune - Mumbai Road, Shivajinagar, Pune : 411005 (India)

Phone : +91-20-66011001 Fax : +91-20-66011010 E-mail : marketing@nichrome.com Website : www.nichrome.com

Factory Site : 'Shrimal', Wing, Taluka - Khandala, District - Satara

Offices and Service Centres at : India ASEAN Middle East SAARC CIS Africa

