

BOTTLE FILLING LINE: SOLID

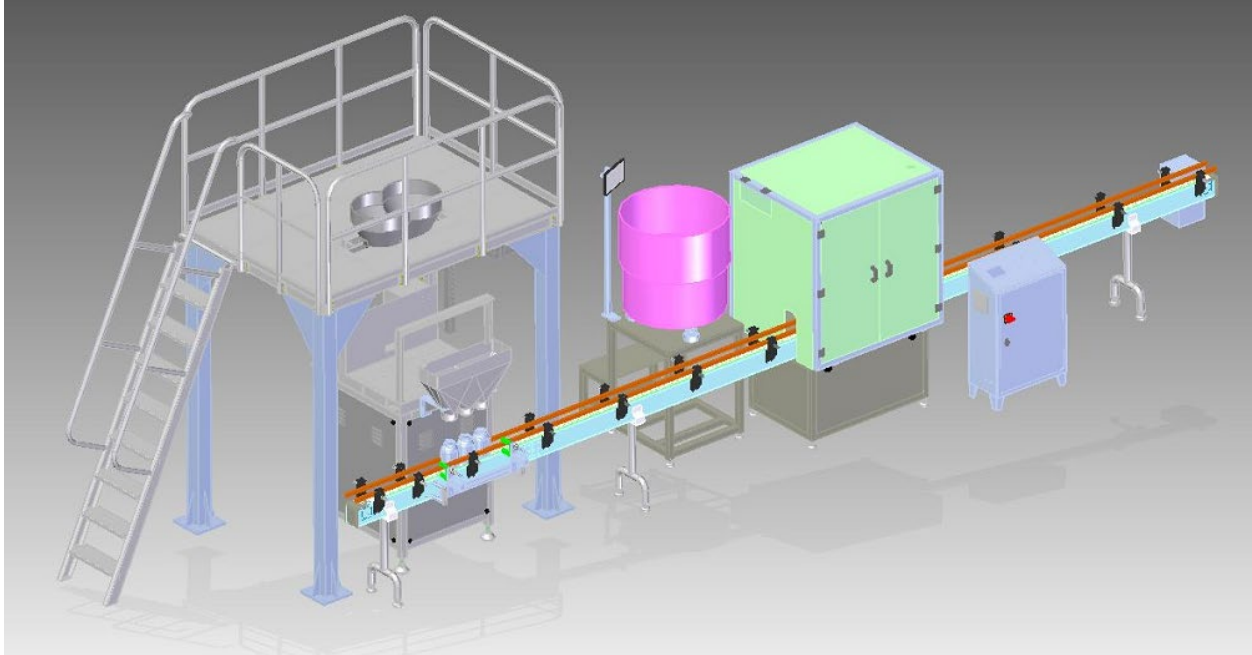

KEY FEATURES

- NO BOTTLE NO FILLING SAFETY DEVICE.
- AUTO CAP PLACING, PRESSING & SCREWING FEATURE AVAILABLE.
- GLASS, HDPE, PP BOTTLES FRIENDLY LINE.
- MACHINE CONSTRUCTION AVAILABLE IN SS304 , SS316 & M.S PAINTED
- PLC CONTROLLED LINE.
- FAST CHANGEOVER DESIGN FOR DIFFERENT SIZE OF BOTTLE.
- DIGITAL LCD TOUCH SCREEN DISPLAYING & SETTING.
- SAFETY ENCLOSURES WITH INTERLOCKS FOR ROTARY PARTS.
- VARIOUS BOTTLES STERILIZATION & CLEANING OPTIONS AVAILABLE.

BOTTLE FILLING LINE – GENERAL ARRANGEMENT DRAWING

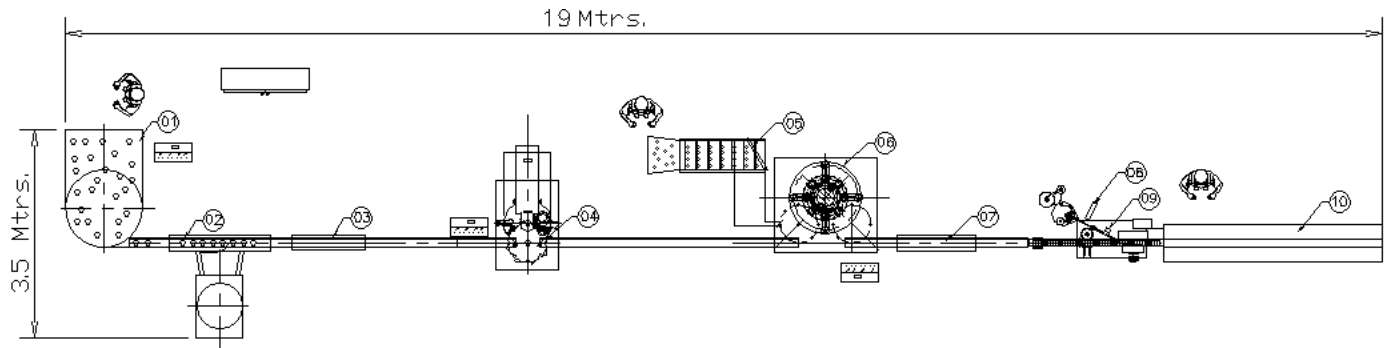

SR.NO.	ITEM DESCRIPTION	QTY
1	TURN TABLE(OD 1200)	1
2	BOTTLE CLEANING SYSTEM	1
3	U V STERLIZATION CHAMBER	1
4	SERVO AUGER FILLER	1
5	CAP FEEDING ELEVATOR	1
6	ROTARYCAPPING MACHINE	1
7	INDUCTION SEALER	1
8	FRONT AND BACK LABELING MACHINE	1
9	DATE AND BATCH CODING SYSTEM	1
10	PACKING TABLE	1

Bottle Filling Product Range:

PRODUCT	FILLER	SKU	SPEED	FLOOR SPACE
MILK POWDER, PROTINE POWDER, CHOCOLATE POWDER, PHARMA POWDERS, COFFEE, BLENDED SPICE POWDERS, PREMIX, NUTRI POWDER, SEASONING POWDER, SUGAR FREE	AUGER FILLER	10 GMS TO 1000 GMS	UP TO 100 BPM	3.5 MTRS WIDE X 20 MTRS LONG X 3 MTRS HEIGHT
TEA POWDER, DETERGRNT POWDER, PANMASALA, PULSES, RICE, SUGAR, SEASONING, SALT	CUP FILLER	10 GMS TO 1000 GMS	UP TO 100 BPM	3.5 MTRS X 20 MTRS X 3 MTRS HEIGHT
TEA POWDER, PULSES, RICE, WRAPPED CANDIES, DRYFRUITES, TABLETS, WHOLE SPICES, SOYA CHUNKS, SEASONING MIX, SUGAR FREE TABLETS	MULTI HEAD WEIGHER	10 GMS TO 1000 GMS	UP TO 100 BPM	4.5 MTRS X 20 MTRS X 4 MTRS HEIGHT
TEA POWDER, PULSES, RICE, SUGAR, WHOLE SPICES	ELECTRONIC WEIGH FILLER	10 GMS TO 1000 GMS	UP TO 100 BPM	4.5 MTRS X 20 MTRS X 4 MTRS HEIGHT

SPECIFICATION	DIAMETER		HEIGHT	
	MIN.	MAX.	MIN.	MAX.
BOTTLE	Ø 40 mm	Ø 125 mm	50 mm	300 mm
CAP	Ø 28 mm	Ø 80 mm	-	-
INNER PLUG	Ø 25 mm	Ø 50 mm	-	-