



**V F F S**



## **NICHROME**

### **Excel 400 Series**

Flexible and Efficient  
Packaging Solutions

- Latest technology solutions
- Accurate
- Versatile



Servo Auger Filler



Multi-head Weigh Filler



Intelligent Electronic Weigh Filler



Cup Filler



**NICHROME**  
Packaging Solutions

An ISO 9001:2015 and ISO 22000:2005 Certified Company

[www.nichrome.com](http://www.nichrome.com)

### Salient Features

- CE marked PLC Controller & touch screen HMI equipped for automation
- AC motor driven bag length control mechanism
- Belt draw-off system for positive and accurate film pulling
- Pneumatic/Servo Motor driven horizontal sealing mechanism
- Proportionate cross sealing jaw opening for optimum performance
- Motorized precise film reel unwinding mechanism
- Print mark scanner to use panel printed films
- Static charge eliminator
- Quick & easy size change over
- Integration to upstream and downstream allied equipment.
- Built-in Jumbo Roll Trolley for increased productivity.
- Optional Swing on filler to offer common solution for Powder & Grains

### Technical Specifications

Bagger Speed (up to)	60 Bags/min
Quantity (100cc to 20,000cc)	Up to 10 kg
Pack Size Range	
Min. Pouch Size (WxL)	100 mm x 160 mm
Max. Pouch Size (WxL)	400 mm x 530 mm
Horizontal Table	Pneumatically Driven (Servo Motor driven option available)
Packaging Material	Heat sealable laminate or Co-ex films
Heat System	Constant/Impulse Seal System
Supply Voltage	Stabilized 415V AC, 3 phase, 50Hz
Connected Load	4 kW
Air Consumption	35 m/hr @ 6 bar

### Filler Options & Applications

Category	Food	Non Food
<b>Excel 400 Plus Servo Auger</b>	Atta (flour products), Milk Powder, Spice Powders, Coffee Powder, Premixes, Instant Mixes	Agro Chemicals, Pesticides, Mould powder (foundry), Red Oxide powder
<b>Excel 400 Plus Multi head Weigher</b>	Potato Chips, Macroni, Pasta, Indian Namkeen, Puffed Snacks, Dry fruits, Nuts, Candies, Soya Chunks, Tea, Breakfast Cereals, High Counts Biscuits, Whole Spices, Sooji, Pulses	Crop Seeds, Vegetable seeds, Pet foods
<b>Excel 400 Plus Intelligent Linear Electronic Weigh Filler</b>	Grains, Pulses, Rice, Sugar, Tea, Whole Spices	Crop Seeds
<b>Excel 400 Plus Volumetric Cup Filler</b>	Grains, Pulses, Sugar, Rice, Salt	Detergent

\*Excel 600 model available for bulk packaging solutions.

### Pouch Formats

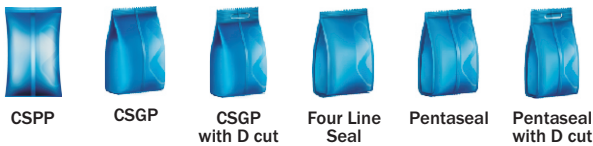

### Optional Accessories

- Rectangular Forming Size Parts
- Side Gusset Mechanism & Block Bottom Device
- Splicing Table for quick film joining
- Straight Line Cut Facility
- Impulse Change-over System to use co-ex films
- Gift/Leaflet Insertion System
- Remote access facility for Maintenance of Automation

### Allied Equipment

- Dynamic Check Weigher with tendency control facility for powders
- On-line Digital Metal Detection System
- Date/Batch Coding Devices i.e. TTO /Ink jet/Hot foil/Contact type printer
- Dust Extraction System
- Pouch in Pouch (PIP) System
- Baling Machine for secondary packing

### Excel 400

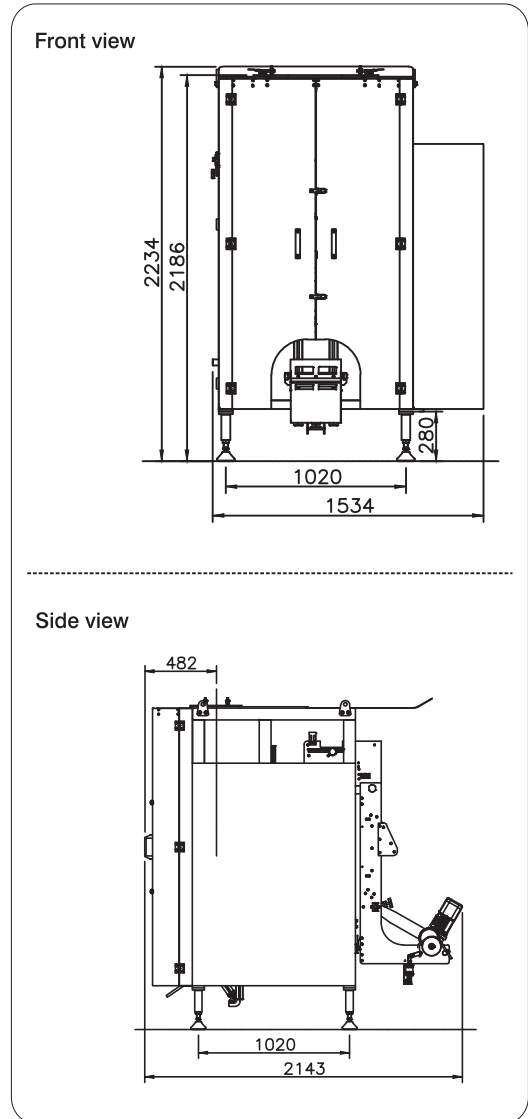

Terms & Conditions  
 1. Speeds and accuracies mentioned are at ideal conditions and may vary depending upon product being packed and packaging material used.  
 2. We reserve the right to incorporate changes, modify and upgrade as found appropriate for specific application of packaging so as to fine tune the product with machine.  
 3. Specifications are subject to change without notice.  
 4. Photographs are for reference only and actual models may vary.

www.intertecdesigns.com



**NICHROME**  
Packaging Solutions

**NICHROME INDIA LTD.** Safire Park Galleria, 4, Pune - Mumbai Road, Shivajinagar, Pune - 411 005, India  
 Tel.: +91 - 20 - 6601 1001 Fax: +91 - 20 - 6601 1010 E-mail: marketing@nichrome.com [www.nichrome.com](http://www.nichrome.com)

Service Centres & Offices at: Delhi | Kolkata | Mumbai | Bangalore | Hyderabad | Chennai | Ahmedabad | Chandigarh | Kanpur  
 ASEAN | MIDDLE EAST | SAARC | RUSSIAN FEDERATION & CIS | AFRICA | USA

Packaging Solutions For • Liquids • Grains • Powders • Seeds • Snacks • Pharma • Personal Care